

Quick Mating Miniature Waterproof Circular Connectors

HR34B Series



■ Features

1. Bayonet Lock

- Quick and accurate connection with a self-locking bayonet collar.

2. Alignment marks

Clearly visible alignment marks on plug and receptacle allow easy alignment when mating.

3. Water and dust protection

- IP67 water and dust protection rating when fully mated.
- 4-position receptacles are sealed against water penetration when mounted on the panel - no protective cap is required.
- Resistant to industrial grade oils

4. Several configurations and termination styles

- Number of positions: 4, 10
- Plugs: Straight and right-angle, wire solder and crimp terminations
- Receptacles: Panel mount, wire solder and through-hole terminations

5. Multi-directional cable exit

Right angle plugs allow the cable to exit in 8 directions, in 45° increments.

6. Safety standards

The 4-positions connectors meet requirements of TÜV standard.

7. RoHS compliant

All components and materials comply with the requirements of EU Directive 2002/95/EC

■ Applications

Construction and industrial equipment, robots, servo motors and a other applications requiring high reliability miniature waterproof circular connectors.

Illustrations of mated connectors

Right angle plug

Straight plug

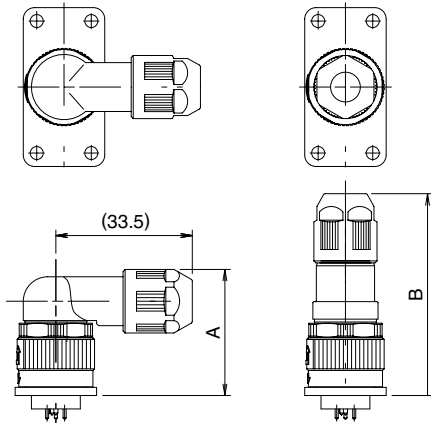

Mating Combinations	A
10 pos. : Right-angle plug + receptacle through-hole	31.0
10 pos. : Right-angle plug + receptacle wire solder	31.5
4 pos. : Right-angle plug + receptacle wire solder	31.3

Mating Combinations	B
10 pos. : Straight plug + receptacle through-hole	49.6
10 pos. : Straight plug + receptacle wire solder	50.1
4 pos. : Straight plug + receptacle wire solder	49.6

Bayonet Lock

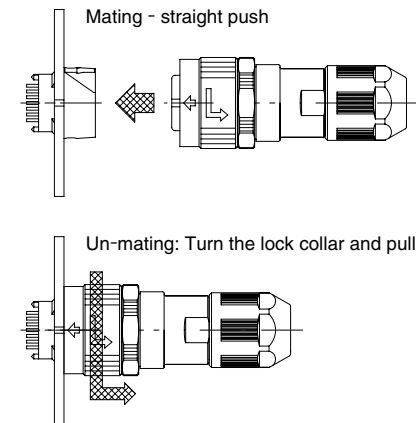

Cable exit directions

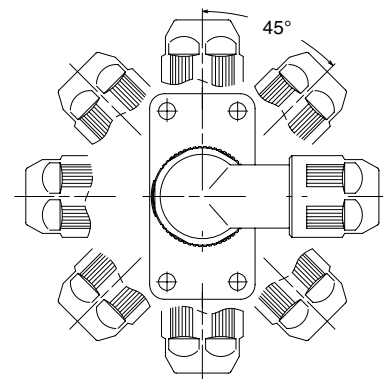

■ Specifications

Ratings	Current rating	10 pos.: 3 A 4 pos.: 5 A	Operating temperature range	-25°C to 85°C (Note 1)
	Voltage rating	10 pos.: 200 V AC, 250 V DC 4 pos.: 200 V AC, 200 V DC (contamination level 3) 400 V AC, 400 V DC (contamination level 2)	Storage temperature range	-25°C to 85°C (Note 2)

Item	Specification	Conditions
1.Contact resistance	30 mΩ max.	1 A DC
2.Insulation resistance	1,000 MΩ min.	500 V DC
3.Withstanding voltage	No flashover or insulation breakdown	10 pos.: 900 V AC / 1 minute 4 pos.: 2,000 V AC / 1 minute
4.Vibration	No electrical discontinuity of 10 μs or longer	Frequency: 10 to 500 Hz/cycle, total amplitude of 0.75 mm, 98m/s ² each, 3 hours in 3 axis.
5.Shock	No electrical discontinuity of 10 μs or longer	Acceleration of 490 m/s ² , 11 ms duration, 3 axis, each for 3 hours
6.Durability (Mating / un-mating)	Contact resistance: 30 mΩ max.	500 cycles
7.Temperature cycle	Insulation resistance: 500 MΩ min.	Temperature : -55°C → +15° to +35°C → +85°C → +15° to +35°C Time : 30 min. → 10 to 15 min. → 30 min. → 10 to 15 min. 5 cycles
8.Humidity	Insulation resistance: 50 MΩ min. (at high humidity) Insulation resistance: 500 MΩ min. (when dry)	336 hours at 71°C, and humidity of 95%
9.Water protection	No water penetration when submerged for 48 hours at the depth of 1.8 meters.	

Note 1: Includes temperature raise caused by the current flow.

Note 2: The term "storage" refers to connectors stored for the long period of time prior to mounting and use.

■ Materials

● Plugs

Part	Material	Finish	Remarks
Outer shell	Zinc alloy, aluminum alloy, and polyamide resin (black)	Black chrome plating, black chromate finish (Cr +3)	_____
Insulator	PPS	Color: Black	UL94V-0
Female contacts	10 pos.	Phosphor bronze	Gold plated
	4 pos.	Copper alloy	Silver plated
O-ring Gasket	Fluororubber, Nitrile hydride rubber	_____	_____

● Receptacles

Part	Material	Finish	Remarks
Outer shell	Zinc alloy	Black chromate finish (Cr +3)	_____
Insulator	PPS	Color: Black	UL94V-0
Male contacts	10 pos.	Copper alloy	Gold plated
	4 pos.	Brass	Silver plated
Ground contact	10 pos.	Brass	Gold plated
	4 pos.		Silver plated
O-ring	Fluororubber	_____	_____

■ Ordering information

HR34B - 12 WP A - 10 S - X

① ② ③ ④ ⑤ ⑥ ⑦

① Series name : HR34B Series	⑤ Number of contact : Number of contacts. (Excluding ground contacts)
② Shell size : Diameter (mm) of the mating interface of the plug	⑥ Contact type S : Female wire solder P : Male wire solder PD : Male, through hole contact SC : Female crimp
③ Shell style WP : Straight plug WLP : Right-angle plug WR : Receptacle	
④ Shell configuration : Combination of the cable exit diameter, tightening collar diameter and the distance from mating face to center of the outer shell, designated with the letters A, B, D e.t.c. (letters C, J, P and R will not be used).	⑦ Keying Blank : Standard X : X key position

Plugs

●Straight - wire solder

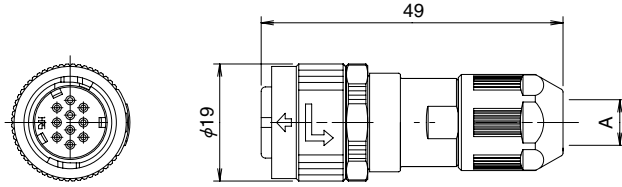

All dimensions: mm

Part Number	CL No.	A	Applicable cable diameter range	Solder cup inner diameter	RoHS
HR34B-12WPA-10S(71)	134-0004-7-71	$\phi 7.4$	$\phi 5.7$ to 7.3	$\phi 1$	YES
HR34B-12WPB-10S(71)	134-0007-5-71	$\phi 8.5$	$\phi 6.5$ to 8.0		
HR34B-12WPD-4S	134-0020-3-00	$\phi 7.4$	$\phi 5.7$ to 7.3	$\phi 1.7$	
HR34B-12WPD-4S-X	134-0023-1-00				
HR34B-12WPE-4S	134-0025-7-00	$\phi 8.5$	$\phi 6.5$ to 8.0		
HR34B-12WPE-4S-X	134-0031-0-00				

●Crimp (separate contacts required)

Part Number	CL No.	A	Applicable cable diameter range	RoHS
HR34B-12WPA-10SC	134-0017-9-00	$\phi 7.4$	$\phi 5.7$ to 7.3	YES
HR34B-12WPB-10SC	134-0028-5-00	$\phi 8.5$	$\phi 6.5$ to 8.0	

●Right angle - wire solder

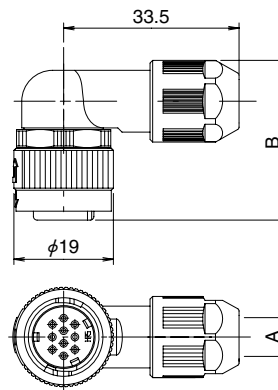

All dimensions: mm

Part Number	CL No.	A	B	Applicable cable diameter range	Solder cup inner diameter	RoHS
HR34B-12WLPA-10S(71)	134-0005-0-71	$\phi 7.4$	30.5	$\phi 5.7$ to 7.3	$\phi 1$	YES
HR34B-12WLPB-10S(71)	134-0008-8-71	$\phi 8.5$		$\phi 6.5$ to 8.0		
HR34B-12WLPD-4S	134-0030-7-00	$\phi 7.4$	30.85	$\phi 5.7$ to 7.3	$\phi 1.7$	
HR34B-12WLPD-4S-X	134-0034-8-00					
HR34B-12WLPE-4S	134-0035-0-00	$\phi 8.5$	$\phi 6.5$ to 8.0			
HR34B-12WLPE-4S-X	134-0036-3-00					

●Crimp (separate contacts required)

Part Number	CL No.	A	Applicable cable diameter range	RoHS
HR34B-12WLPA-10SC	134-0018-1-00	$\phi 7.4$	$\phi 5.7$ to 7.3	YES
HR34B-12WLPB-10SC	134-0029-8-00	$\phi 8.5$	$\phi 6.5$ to 8.0	

HR34B Series Quick Mating Miniature Waterproof Circular Connectors

■ Receptacle

● Wire solder

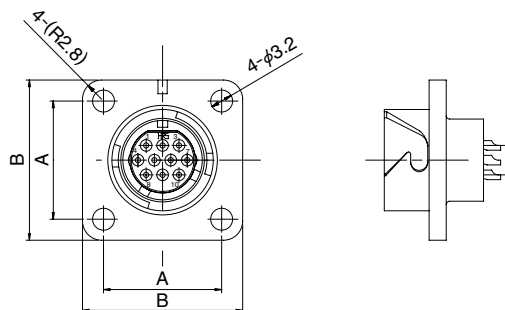
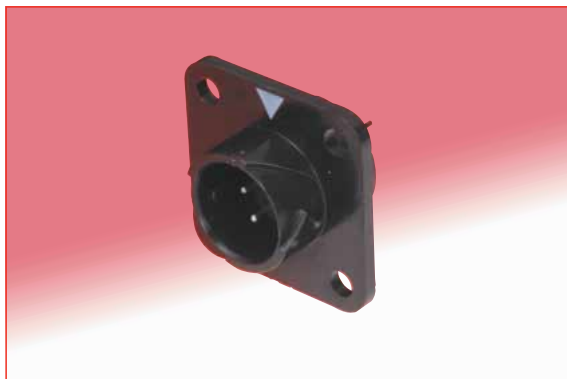

All dimensions: mm

Part Number	CL No.	A	B	Solder cup inner diameter	RoHS
HR34B-12WRA-10P	134-0016-6-00	17.26	23.4	φ1	YES
HR34B-12WRB-4P	134-0021-6-00	18.26	25.4	φ1.3	
HR34B-12WRB-4P-X	134-0024-4-00				

Note : Not supplied for O-ring. Use commercially available O-ring.

● Through hole

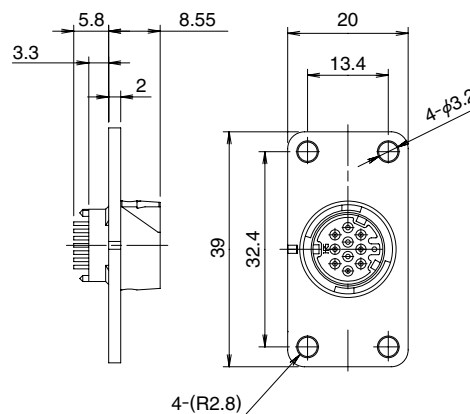

All dimensions: mm

Part Number	CL No.	RoHS
HR34B-12WR-10PD(71)	134-0003-4-71	YES

Note : Not supplied for O-ring. Use commercially available O-ring.

■ Crimp contacts

● Female

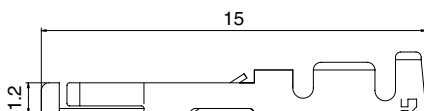

All dimensions: mm

Part Number	CL No.	Packaging	Applicable conductor	RoHS
HR34B-SC-111	134-0022-9-00	100 pcs. per bag	AWG #20 - 25	YES
HR34B-SC-211	134-0019-4-00	10,000 pcs. per reel		

Note: Use wire with a jacket diameter of 1.7mm max.

■ Connector Mating Combinations

10 pos. Plugs

Straight, Wire Solder or Crimp (Standard key position)
 HR34B-12WPA-10S,10SC
 HR34B-12WPB-10S,10SC

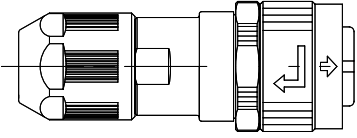

Right angle, Wire Solder or Crimp (Standard key position)
 HR34B-12WLPA-10S,10SC
 HR34B-12WLPB-10S,10SC

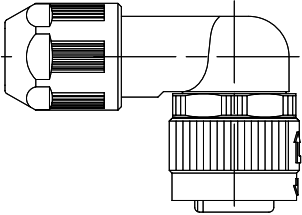

10 pos. Receptacles

Through hole
 HR34B-12WR-10PD

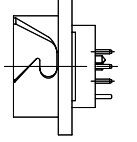

Wire Solder
 HR34B-12WRA-10P

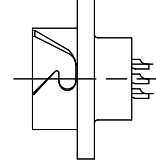

4 pos. Plugs

Straight, Wire Solder (Standard key position)
 HR34B-12WPD-4S
 HR34B-12WPE-4S

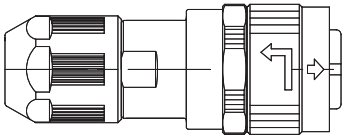

Right angle, Wire Solder (Standard key position)
 HR34B-12WLPD-4S
 HR34B-12WLPE-4S

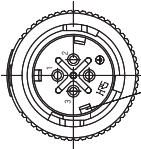
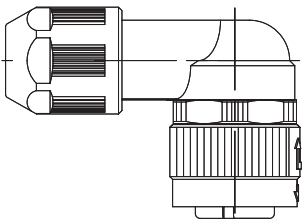

Standard polarizing key

4 pos. Receptacles

Wire solder (Standard key position)
 HR34B-12WRB-4P

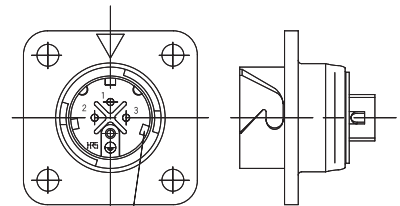

Standard key position

Straight, Wire Solder (X key position)
 HR34B-12WPD-4S-X
 HR34B-12WPE-4S-X

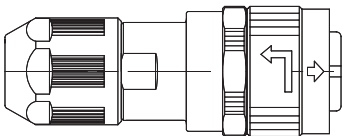

Right angle, Wire Solder (X key position)
 HR34B-12WLPD-4S-X
 HR34B-12WLPE-4S-X

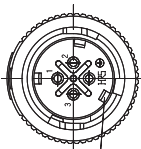
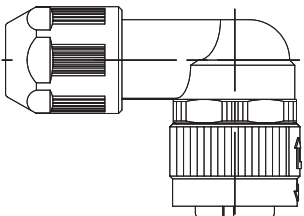

X key position

Wire solder (X key position)
 HR34B-12WRB-4P-X

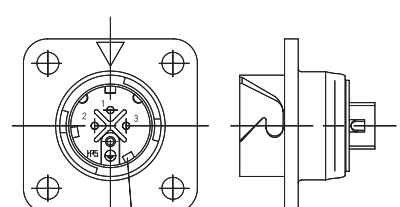

X key position

HR34B Series Quick Mating Miniature Waterproof Circular Connectors

■Applicable tools

Description	Part Number	CL No.	Applicable contact
Manual contact crimping tool	HT/102/HR34B-1	902-1511-1	HR34B-SC-111
Press	CM-105	901-0005-4	HR34B-SC-211
Applicator	AP105-HR34B-1	901-2051-2	
Contact extraction tool	RP6-SC-TP	150-0039-0	HR34B-SC-111, HR34B-SC-211

●Manual contact crimping tool



●Press CM-105 (Applicator ordered separately)



●Contact extraction tool



◆ Recommended panel cutouts

● Receptacle - wire solder

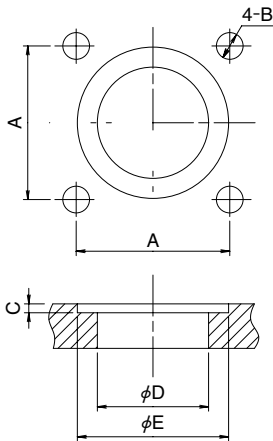

All dimensions: mm

	HR34B-12WRA-10P	HR34B-12WRB-4P HR34B-12WRB-4P-X
A	17.26±0.05	18.26±0.05
B	M3×0.5	
C	1 0/-0.1	1.1 0/-0.1
D	12.5 +0.1/0	16.3 +0.1/0
E	17 +0.1/0	20.8 +0.1/0

Recommended O-ring dimension

	Cross-section dia.	Inner dia.
HR34B-12WRA-10P	1.5	11.5
HR34B-12WRB-4P	1.5	15.5
HR34B-12WRB-4P-X		

● Receptacle - through hole

All dimensions: mm

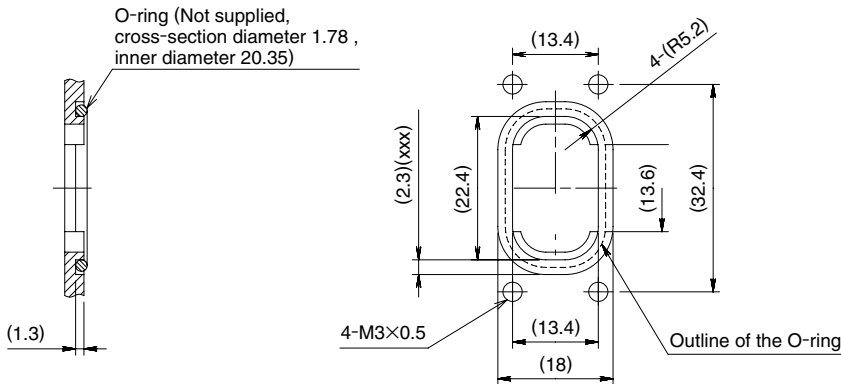

Notes 1: The receptacle panel cutout shows the view from the mating side of the connector.

◆ PCB mounting pattern

● Receptacle - Through hole

All dimensions: mm

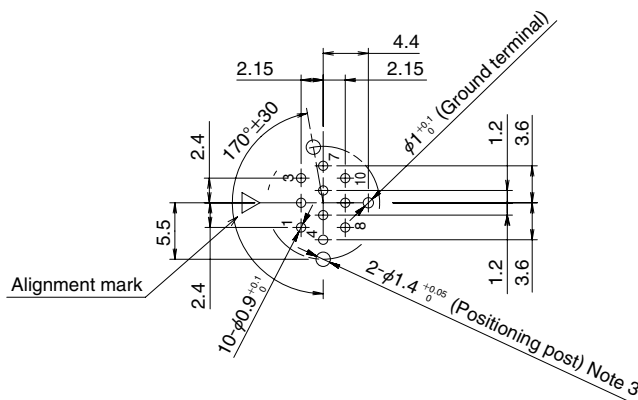

Note 1: The contact configuration shows the view from the mating side.

Note 2: Tolerance of ±0.05 mm is recommended for the plated through hole location and diameter.

Note 3: Not a plated-through holes.

Plugs - Termination procedures

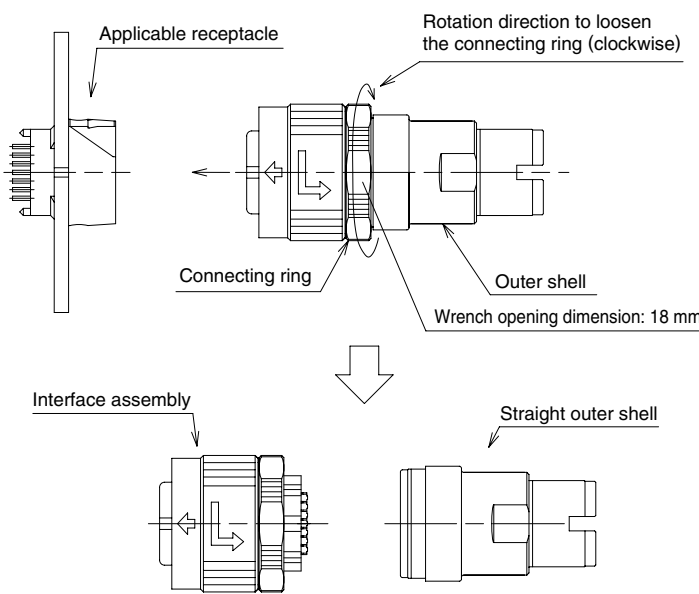
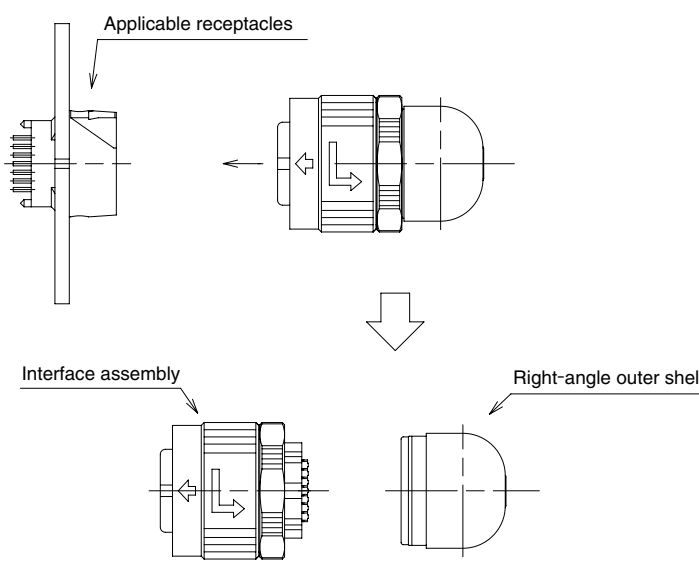
No.	Illustration	Operation
1	<p>■Straight plugs</p>  <p>■Right-angle plugs</p> 	<p>◆Disassembly of connectors</p> <p>After mating to an applicable receptacle, carefully loosen the connecting ring (rotate clockwise) and remove the straight (or right angle) outer shell.</p>

No.	Illustration	Operation															
2	<p>Illustration</p> <p>■Straight plugs</p> <p>■Right-angle plugs</p>	<p>◆Connector assembly furnishings</p> <p>Using spray, brush or another method, coat all threads of the following parts with Loctite 7649 (primer) (or equivalent) manufactured by Henkel Japan Ltd.</p> <ol style="list-style-type: none"> (1) Interface assembly (inner thread) (2) Straight (or right angle) outer shell (outer threads) (3) Tightening collar (inner thread) <p>Allow for full drying in a well ventilated area (30 to 70 seconds), assuring that there is NO contamination of the coated areas.</p> <p>· Passing of the cable through connector parts</p> <p>Pass the cable through the individual parts as shown on the illustration (in the correct order) making sure that the termination end is on the correct side.</p>															
3	<p>Illustration</p> <table border="1" data-bbox="284 1808 828 2000"> <thead> <tr> <th></th> <th>A</th> <th>B</th> </tr> </thead> <tbody> <tr> <td>10-position, wire solder</td> <td>15⁺¹₀</td> <td>2±0.5</td> </tr> <tr> <td>10-position, crimp</td> <td>20⁺¹₀</td> <td>3.2±0.3</td> </tr> <tr> <td>4-position, wire solder straight</td> <td>16⁺¹₀</td> <td>5±0.5</td> </tr> <tr> <td>4-position, wire solder right-angle</td> <td>20⁺¹₀</td> <td>5±0.5</td> </tr> </tbody> </table>		A	B	10-position, wire solder	15 ⁺¹ ₀	2±0.5	10-position, crimp	20 ⁺¹ ₀	3.2±0.3	4-position, wire solder straight	16 ⁺¹ ₀	5±0.5	4-position, wire solder right-angle	20 ⁺¹ ₀	5±0.5	<p>◆Termination of the cable</p> <p>Using correct tools strip the cable and individual wires per the dimensions shown in the table. Observe the allowed tolerances and avoid damage to the insulation or conductors.</p>
	A	B															
10-position, wire solder	15 ⁺¹ ₀	2±0.5															
10-position, crimp	20 ⁺¹ ₀	3.2±0.3															
4-position, wire solder straight	16 ⁺¹ ₀	5±0.5															
4-position, wire solder right-angle	20 ⁺¹ ₀	5±0.5															

HR34B Series Quick Mating Miniature Waterproof Circular Connectors

No.	Illustration	Operation
4	<p>The illustration is divided into four numbered steps:</p> <ul style="list-style-type: none"> Step 1: Shows a cable with conductors being prepared. Heat-shrink tubing is applied to the conductors, and a piece of tape is wrapped around the assembly. A 4mm length is indicated for the tape. Step 2: Shows the prepared assembly being inserted into a receptacle. The assembly is held in place by a fixture. Step 3: Shows the assembly being soldered. Solder is applied to the conductors as they enter the receptacle cups. Step 4: Shows the heat-shrink tubing being slid forward over the solder joints and then shrunk against the insulator body of the receptacle. 	<p>◆Wire termination of the connector 4-1 10-position wire solder</p> <ol style="list-style-type: none"> ① Pre-solder the exposed conductors making sure that no individual strands are protruding. ② Prepare 4 mm long pieces of appropriate heat-shrink tubing and pass each over the wires toward the outer insulation of the cable, as shown on the illustration. Secure each of them temporary to the outer insulation. Note: The heat-shrink tubing will need to be moved over the solder joints after the completion of the soldering process. ③ Mate the Interface assembly with the corresponding receptacle secured in a holding fixture (not supplied) or secure it by other means. Assure correct orientation and complete lock. Fully insert individual conductors in the corresponding solder cups and solder one at the time. Assure that the solder compound has melted sufficiently and the solder joints are secure. ④ Slide forward each of the heat-shrink tubing over the solder joints making sure that it rests against the surface of the insulator. Using a heat gun shrink each over the solder joints. Exercise caution not to damage the wire and cable insulation or other components.

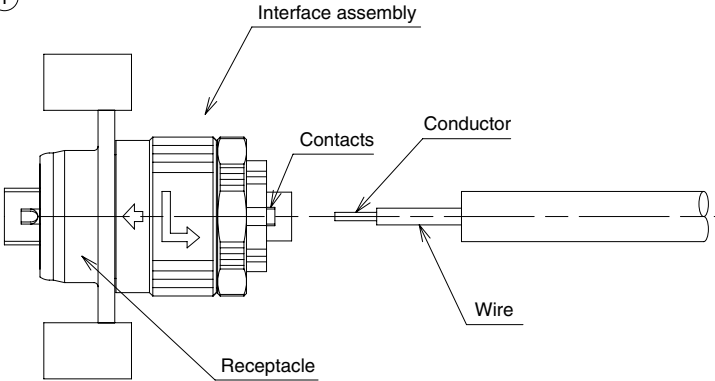
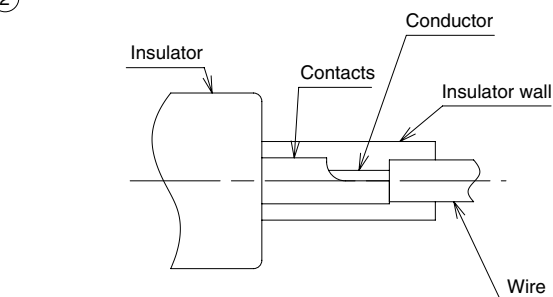
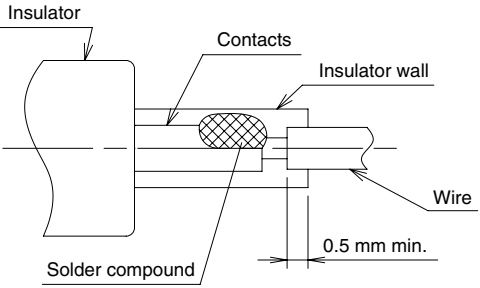
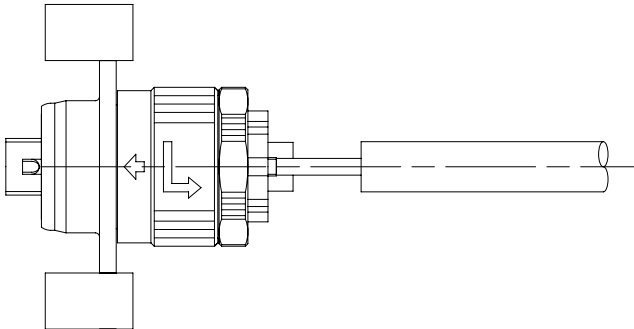
No.	Illustration	Operation
4	<p>①</p>  <p>②</p>   	<p>4-2 4-position wire solder</p> <p>① Pre-solder the exposed conductors making sure that no individual strands are protruding.</p> <p>Mate the Interface assembly with the corresponding receptacle secured in a holding fixture (not supplied) or secured by other means. Assure correct orientation and complete lock.</p> <p>② Fully insert individual conductors in the corresponding solder cups and solder one at the time, assuring the correct position in relation to the insulator walls (as illustrated), with the wire insulation 0.5 mm min. below the edge of the insulator wall.</p> <p>Assure that the solder compound melted sufficiently and the solder joints are secure.</p> <p>Note: Secure that the solder compound has melted sufficiently and the solder joints are secure.</p>

No.	Illustration	Operation
5	<p>■ Straight plugs</p> <p>① ②</p> <p>Interface assembly</p> <p>12 mm max.</p> <p>Cable</p> <p>Protrusion in the outer shell</p> <p>Slot</p> <p>Receptacle</p> <p>Connecting ring</p> <p>Tightening direction of the connecting ring (counter-clockwise)</p>	<p>◆ Assembly of connectors</p> <p>① Bring the insulation edge of the cable to the dimensions shown on the illustrations (12 mm max. for the straight outer shell, 7 mm max. and 15mm max. for the right angle outer shell) by forming of the wires. Make sure that there is no force applied to the individual solder or crimp joints.</p> <p>It is critical that the 12 mm max. or 7 mm and 15 mm max. dimensions (as applicable) are maintained through the completion of the assembly.</p> <p>Failure to do so may result in failure of the cable strain relief and waterproof performance.</p> <p>② Coat the threads on outer shell with a Loctite 242® (or equivalent) compound.</p> <p>Align the protrusion in the outer shell with the corresponding slot on the back of the Interface assembly, insert and tighten the connecting ring, rotating it counterclockwise (0.9N.m to 1N.m torque).</p> <p>Note : Position the right angle outer shell as required at intervals of 45° with respect to the Interface assembly.</p>
	<p>■ Right-angle plugs</p> <p>① ②</p> <p>7 mm max.</p> <p>15 mm max.</p> <p>Protrusion in the right-angle outer shell</p> <p>Connecting ring</p> <p>Tightening direction of the connecting ring</p>	<p>Installation positions for the right-angle outer shell</p> <p>45°</p>

HR34B Series Quick Mating Miniature Waterproof Circular Connectors

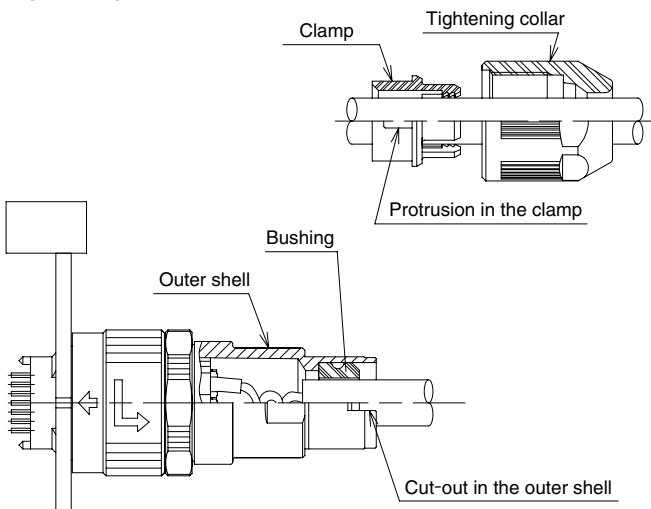
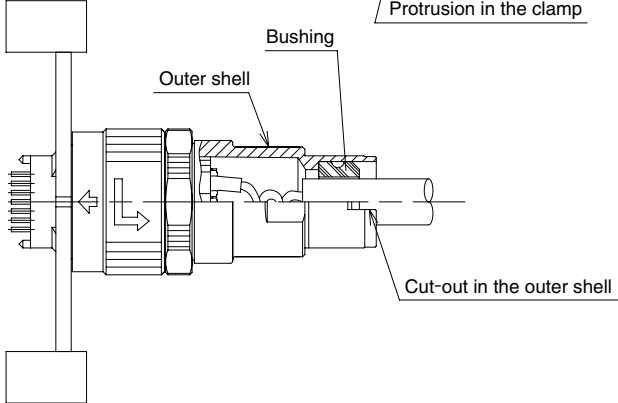
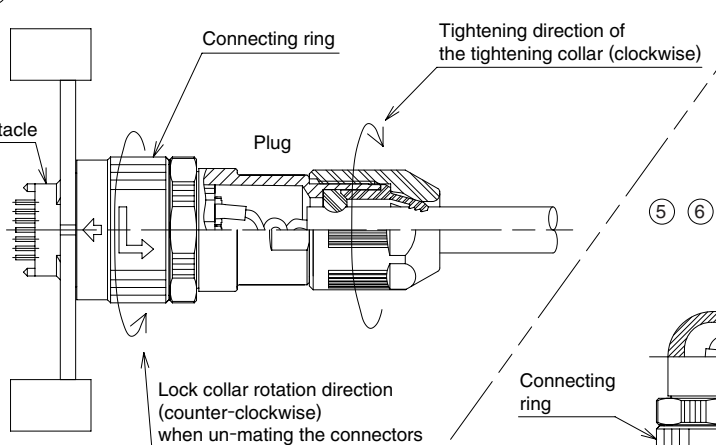
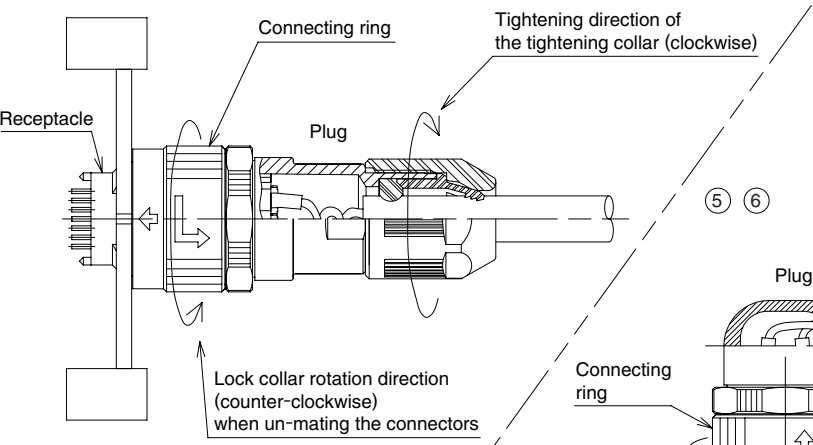
No.	Illustration	Operation
<p>5</p>	<p>■ Straight plugs</p> <p>③</p>  <p>④</p> 	<p>◆ Assembly of connectors (continued)</p> <p>③ Install the bushing at the specified position as indicated in the illustration on the left.</p> <p>④ Install the clamp, making sure that the protrusion fits into the corresponding slot in the outer shell.</p> <p>⑤ Coat the threads on outer shell with a Loctite 242® (or equivalent) compound and attach the tightening collar (0.9N.m to 1N.m torque), making sure that the clamp remains in the correct position.</p> <p>Failure to do so may result in failure of the cable strain relief and waterproof performance.</p> <p>⑥ Turn the lock collar in the direction shown and separate the plug from the receptacle.</p>
	<p>⑤ ⑥</p> 	<p>■ Right-angle plugs</p> <p>⑤ ⑥</p> 

◆ Handling

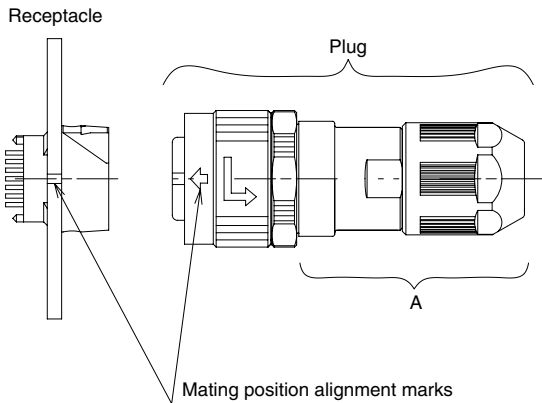
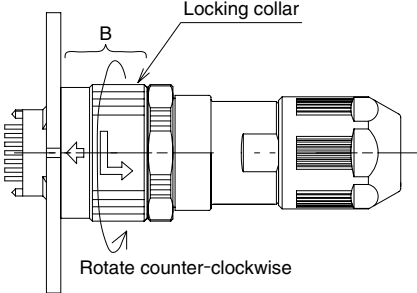
1. Mating	2. Un-mating
 <p>Receptacle</p> <p>Plug</p> <p>Mating position alignment marks</p> <p>A</p> <p>B</p>	 <p>Locking collar</p> <p>B</p> <p>Rotate counter-clockwise</p>
<p>Holding the plug by the outer shell (A) align the arrow on the plug with the alignment mark on the receptacle and push straight in.</p>	<p>Rotate the locking collar counter-clockwise to a full stop and un-mate the plug from the receptacle.</p>

◆ Precautions

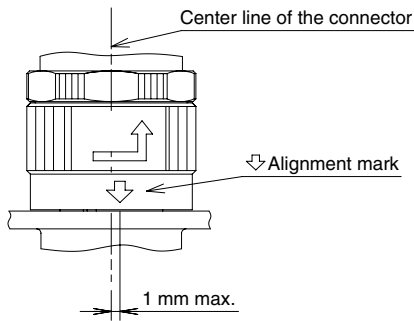

When completely mated and locked the alignment arrow on the plug must line-up with the center line of the connector (alignment mark on the receptacle).

If the alignment arrow and the center line of the connectors are not aligned (1 mm max.) re-insert the plug until they are aligned.

1. Turn-off the power when mating / un-mating the connectors.
2. The shape of the alignment mark may differ (triangle or line) depending on the style of the receptacle.
3. In order to retain the cable strain relief and waterproof performance it is critical that the cable outer diameter is within specified range.